

# Fosroc® Lokfix E35

**Styrene free polyester resin based cartridge system, for anchoring reinforcement and lightweight fixings into a variety of substrates.**

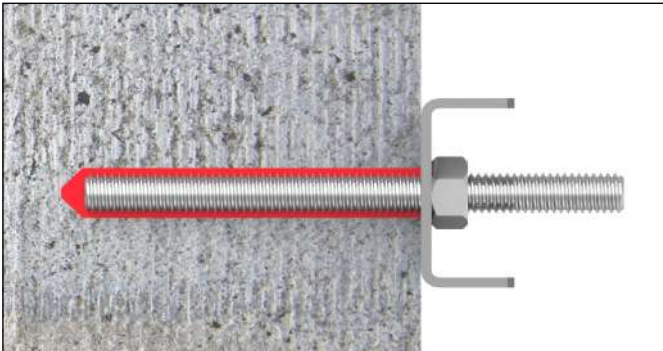

## Uses

For concrete (solid, porous and light), masonry, natural stone and hollow bricks.

- Cost effective alternative for the anchoring of threaded rods, reinforcing bars, profiled rod, steel section with undercut and internal threaded rod sleeves
- Safe application in hollow bricks using a Hollow Block Sleeve
- For horizontal, vertical and overhead application
- Bonding and surface crack sealing applications
- Suitable for dry, wet and flooded concrete

## Advantages

- Fast return to service
- May be used with a good quality skeleton gun (300ml size)
- No additional mixing equipment required
- Does not apply expansive force to the substrate
- Enables fixings closer to edges than mechanical anchors
- Resistant to a variety of chemicals
- Low VOC
- Re-usable by replacing the static mixer
- Waterproof, protecting the fixing from corrosion
- Performs over a wide variety of temperatures

## Description

Lokfix E35 is a two component Polyester anchoring material, supplied in single component cartridges with a static mixer nozzle. When applied it sets and cures rapidly to firmly secure a variety of steel fixings into concrete and masonry substrates.

Three grades of Lokfix E35 are available, selection is normally based upon the substrate installation temperature :

**Lokfix E35S:** Standard temperature grade, optimised for substrate installation temperatures between -5 to +40°C.

**Lokfix E35L:** Low temperature grade, optimised for substrate installation temperatures between -10 to +30°C.

**Lokfix E35T:** Tropical temperature grade, optimised for substrate installation temperatures between +10 to +45°C.

Other grades of Lokfix are also available

**Lokfix E55** Resin anchor cartridge system based on styrene free vinyl-ester for medium to heavy duty anchoring.

**Lokfix E75** Resin anchor cartridge system based on pure epoxy for heavy duty fixings.

## Specification Clause

The anchor grout shall be Fosroc Lokfix E35 cartridge system. The Anchoring grout shall comply with European Technical Assessments, ETA 18/0553 and ETA 18/0552.

## Standards Compliance

**Lokfix E35S, E35L & E35T** comply with the following:

- European approval acc. to EAD 330076-00-0604 product area code: 33 Injection Anchors for use in Masonry (supersedes ETAG TR029)
- European approval acc. to EAD 330499-00-0601 product area code: 33 Injection Anchors for use in uncracked concrete (supersedes ETAG 001 option 5)
- Émissions dans l'air Intérieur : A+
- LEED compliant VOC Level



# Fosroc® Lokfix E35

	
1343	
Fosroc Limited Factory RC1 18 1343- CPR-M 672-1	
ETA-18/0553 EAD-330499-00-0601 Option 7 M8-M24 For use in un-cracked concrete	

	
1343	
Fosroc Limited Factory RC1 18 1343- CPR-M 672-2	
ETA-18/0552 EAD-330076-00-0604 M8-M16 For use in masonry	

**Table 1—Material Properties**

Compressive Strength (EN196)	70MPa
Flexural Strength (EN196)	30 MPa
E Modulus (EN196)	4000 MPa
Density	1.74kg/L
Max permanent service temperature	-40 to +50°C
Max temporary service temperature	-40 to +80°C

## Chemical resistance

Lokfix E35 has resistance to a wide variety of chemicals. Consult Fosroc technical department for specific data.

**Table 2—Lokfix E35S Gel & \*Dry Curing Times**

Substrate Temp.	Gel Time (mins)	*Dry Curing Time (mins)
-5°C	90	360
0 °C	45	180
+5°C	25	120
+10 °C	20	100
+15 °C	15	80
+20 °C	6	45
+30 °C	4	25
+35 to 40 °C	2	20

**Table 3—Lokfix E35L Gel & \*Dry Curing Times**

Substrate Temp.	Gel Time (mins)	*Dry Curing Time (mins)
-10 °C	60	240
-5°C	45	120
0 °C	25	80
+5 °C	10	45
+10 °C	4	25
+15 °C	3	20
+20 to 30 °C	2	15

**Table 4—Lokfix E35T Get & \*Dry Curing Times**

Substrate Temp.	Gel Time (mins)	*Dry Curing Time (mins)
+10 °C	30	300
+15 °C	20	210
+20 °C	15	145
+30 °C	10	80
+35 °C	6	45
+40 °C	4	25
+45 °C	2	20

Note for Lokfix E35 grades the cartridge temperature should be between +15 to +30°C for optimal use. The substrate temperature can vary significantly from the ambient temperature.

\*The tables are for dry conditions. If the substrate is wet double the curing time e.g. for 120 mins dry then 240 mins wet.

## Design Criteria

Note table 5, overleaf, is for dry un-cracked concrete only. For all other conditions including fixings into solid and hollow masonry types, refer to the relevant method statement, or EAD document available through your local technical office.

# Fosroc® Lokfix E35

## Design Criteria

**Table 5 - Setting Parameters – details below**

Un-cracked Concrete Threaded Rod				M8	M10	M12	M16	M20	M24
Anchor Size									
Edge Distance	$1 x h_{ef}$	$C_{cr,N}$	mm	80	90	110	125	170	210
Min. Edge Distance	$5 x d$	$C_{min}$		40	50	60	80	100	120
Axial Distance	$2 x h_{ef}$	$S_{cr,N}$		160	180	220	250	340	420
Min. Axial Distance	$5 x d$	$S_{min}$		40	50	60	80	100	120
Embedment Depth		$H_{ef}$		80	90	110	125	170	210
Min. part thickness		$H_{min}$		$H_{ef} + 30mm$			$H_{ef} + 3d_0$		
Drill Diameter		$d_0$		10	12	14	18	24	28
Brush Diameter		$d_b$		12	14	16	20	26	27
Installation Torque		$T_{inst}$	Nm	10	20	40	60	120	150
Material Consumption			ml	3	4	5	7	24	35

### Assistance and qualification

Design of fixings and reinforcement must be undertaken by suitably qualified personnel with understanding of the construction and use of the structure, the use of the fixing, as well as being in compliance with local legislation.

In applications where fixings must be designed and applied in compliance with the requirements of the ETA, designers should consult the relevant Fosroc accreditation documents.

### Product Installation

The following methodology is for installation into solid substrates such as reinforced concrete. For hollow substrates please request a separate method statement.

Full details are available in the application method statement, a copy of which may be obtained from your local Fosroc technical department.

### Hole Formation and Preparation

Drill hole with percussive drill ensuring sides of the concrete are rough.

If rebar is struck immediately stop drilling and seek the advice of the designing engineer.

Clean holes immediately prior to installation of fixings to avoid them becoming re-contaminated. Standing water in the hole shall be removed prior to preparation.

Using a hand pump or oil free compressed air insert the nozzle to the back of the hole and blow out 4 times.

Insert a wire cleaning brush to the bottom of the hole and brush out 4 times

Using a hand pump or oil free compressed air insert the nozzle to the back of the hole and blow out an additional 4 times.

If dust is still present, repeat the process until no further dust is visible.

Ensure the drill bit and the cleaning brush are of suitable diameter for the fixing used.

### Threaded rod:

Drill bit  $\varnothing$  = rod diameter +2mm

Wire brush  $\varnothing$  = rod diameter +4mm

### Fixings Preparation

Fixings shall be free from rust, paint, grease and contaminants which will interfere with the bond.

# Fosroc® Lokfix E35

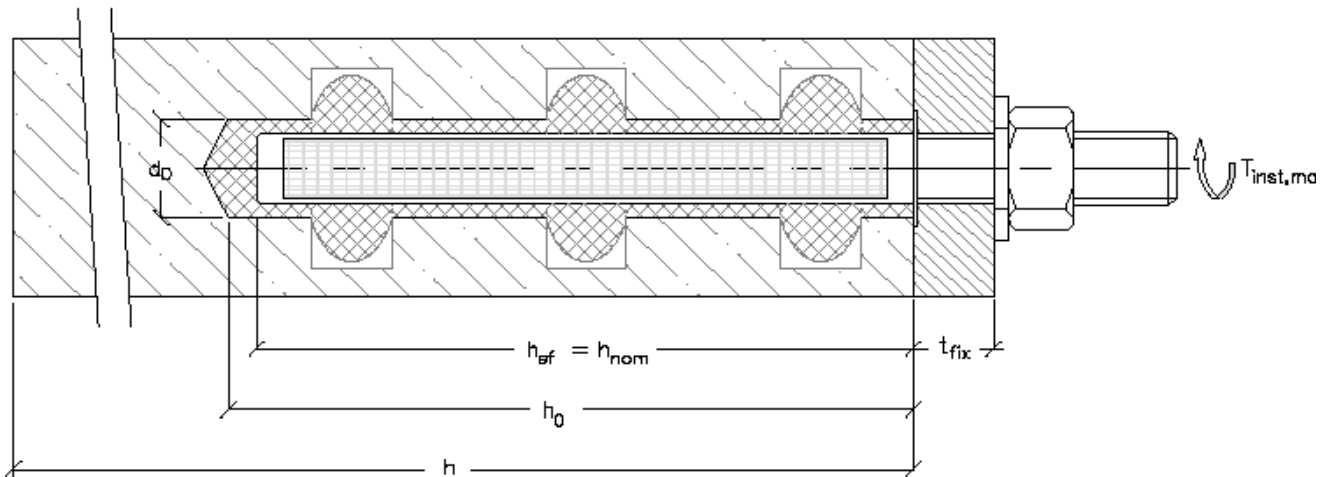

**Figure 1: Use of masonry sleeve in hollow block**

## Installation

Unscrew the fixing cap. Pull the plastic within the tube slightly upwards so that the steel collar is exposed, cut the plastic tube competently removing the metal clip and discard.

Screw the static mixer nozzle onto the cartridge. Place the cartridge into the application gun. Pull the trigger to extrude the Lokfix E35. **Important:** extrude the initial material until the colour becomes grey and consistent. This typically takes two or three full squeezes. Discard material that is streaky in colour. Insert the nozzle to the back of the hole and pump the Lokfix material gently pulling back until the hole is  $\frac{3}{4}$  full. Ensure there are no voids in the resin. If the hole is too deep for the nozzle to reach the back, use a nozzle extender.

In deep, wide or overhead holes a piston plug with a nozzle extender will help reduce slump and ensure a void free application. Mark the required depth on your fixing. Observing the product gel time, insert the fixing into the hole using a gentle twisting motion. Ensure the fixing is inserted to the required depth and is held straight until the resin sets. There should be some extrusion of the Lokfix material from the hole which indicates that there is full embedment.

Do not load or apply tension to the fixing until the product fixing time has been observed, see tables 2, 3 & 4.

Do not over-tighten fixings. Observe maximum installation torque as stated in table 5. If the cartridge is to be re-used, remove the mixing nozzle and re-apply the cap. When using again a new mixing nozzle will be required.

## Cleaning

Wet resin should be removed from tools and equipment using Fosroc Solvent 102 immediately after use.

## Estimating

### Supply

Lokfix E35S E35T and E35L are supplied in boxes of 12 no. 300ml cartridges, each supplied with a single mixer nozzle.

Fosroc may also supply:

- Steel brushes, in various diameters to clean the hole.
- Dust blower pump, one size, hand held to clean the hole.
- Hollow block sleeves, in a variety of diameters and embedded lengths for hollow bricks and blocks.
- Extension nozzle, essential where the embedment depth is greater than 190mm. In various lengths.
- Piston plugs, required where the hole diameter is  $>20\text{mm}$  or where embedment depth is  $>240\text{mm}$ . Must be used with an extension nozzle.
- Application guns, hand held for cartridge application.
- Spare mixer nozzles, required if re-using a cartridge.

### Yield

Standard yield estimation is provided in table 5 based on the hole diameter, fixing size and embedded length. For non-standard consumption the calculation below may be used. Factors such as over-drilling, extrusion from bolt hole, initial gun extrusion and wastage to be considered

# Fosroc® Lokfix E35

---

$(\pi \text{ radius cm hole}^2 - \pi \text{ radius cm bolt}^2) \times \text{hole length cm} =$   
consumption ml.

## Limitations

Load calculations to be undertaken by a qualified engineer.

When embedding into hollow masonry it is normally necessary to use hollow block sleeves. Consult separate method statement.

Attention natural or decorative stone can discolour, check suitability in advance.

Lokfix E35 is not recommended for the following conditions: seismic; cracked concrete and fire rated, consider Lokfix E55 or Lokfix E75. after referring to the respective technical datasheets.

## Storage

300ml cartridges have a maximum shelf life of 12 months when kept in a dry warehouse at between +5 to +25°C.

## Precautions

### Health & Safety

Observe the information provided on the relevant SDS.

©Fosroc is a registered trademark of Fosroc International Limited



## Fosroc Limited

Drayton Manor Business Park  
Coleshill Road, Tamworth,  
Staffordshire B78 3XN. UK

[www.fosroc.com](http://www.fosroc.com)

### Important note

Fosroc products are guaranteed against defective materials and manufacture and are sold subject to its standard Conditions for the Supply of Goods and Services, copies of which may be obtained on request. Whilst Fosroc endeavours to ensure that any advice, recommendation, specification of information it may give is accurate and correct, it cannot, because it has no direct or continuous control over where or how its products are applied, accept any liability either directly or indirectly arising from the use of its products, whether or not in accordance with any advice, specification, recommendation of information given by it.

**telephone:**  
+44 (0)1827 262222

**fax:**  
+44 (0)1827 262444

**email:**  
[enquiryuk@fosroc.com](mailto:enquiryuk@fosroc.com)

